

- (CZ)** NÁVOD K MONTÁŽI
- (EN)** ASSEMBLY INSTRUCTIONS
- (DE)** MONTAGEANLEITUNG
- (ES)** INSTRUCCIONES DE MONTAJE
- (NL)** MONTAGEVOORSCHRIFT
- (IT)** ISTRUZIONI DI MONTAGGIO
- (PT)** INSTRUÇÕES DE MONTAGEM
- (PL)** INSTRUKCJA MONTAŻU
- (CR)** NAPUTCI ZA MONTAŽU

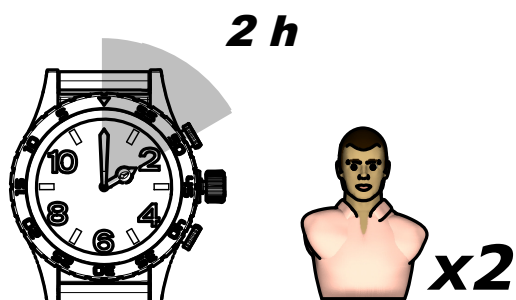

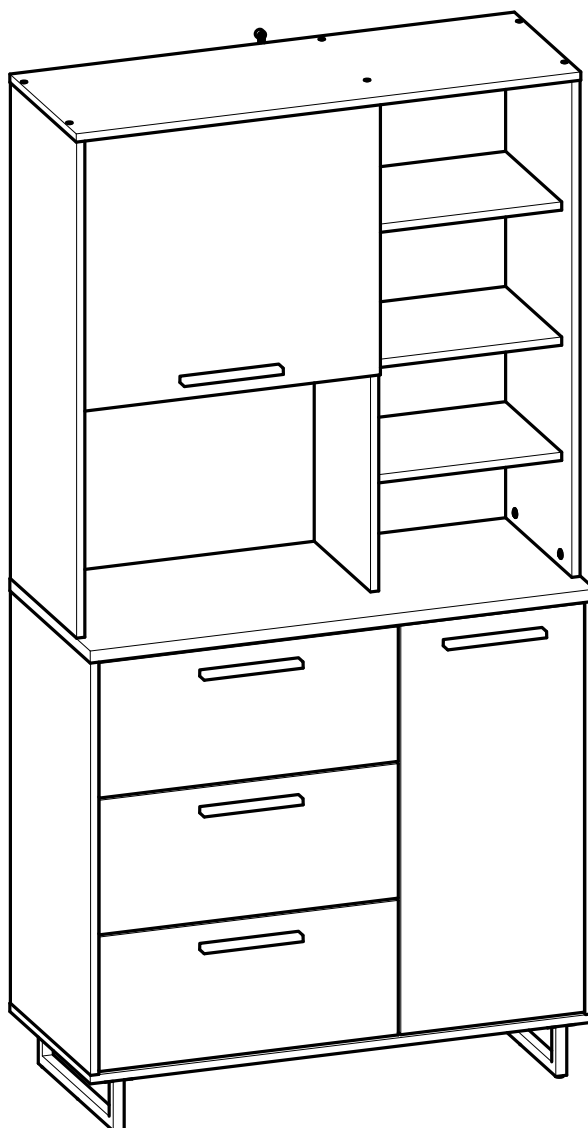

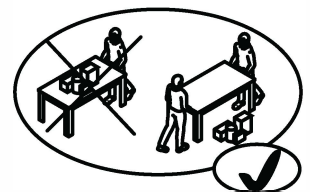
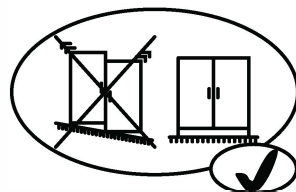
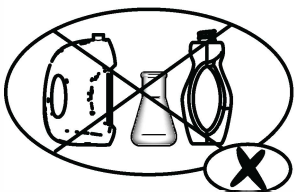
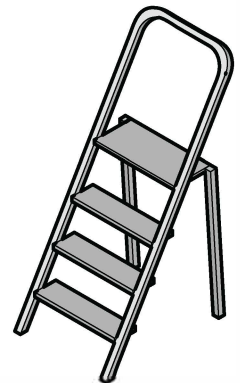
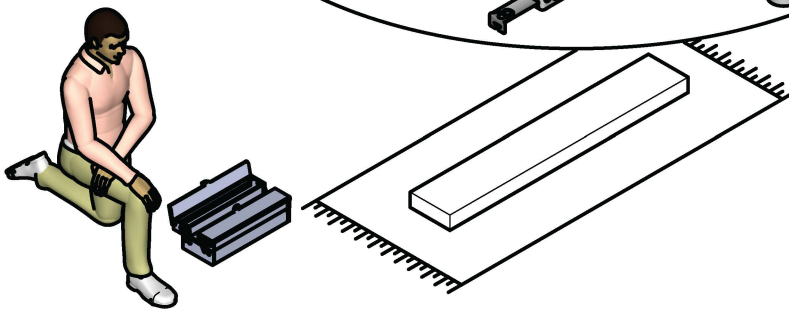
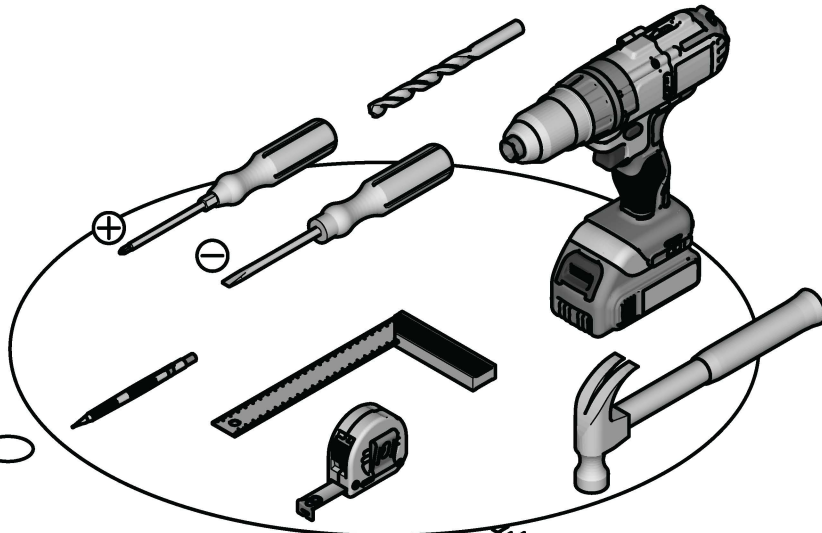
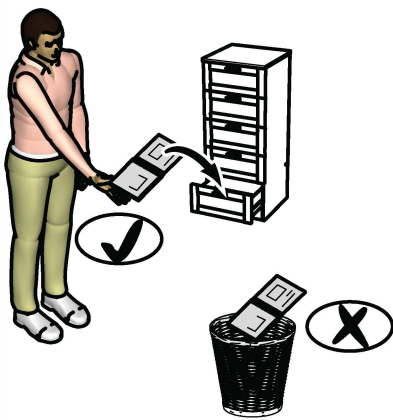
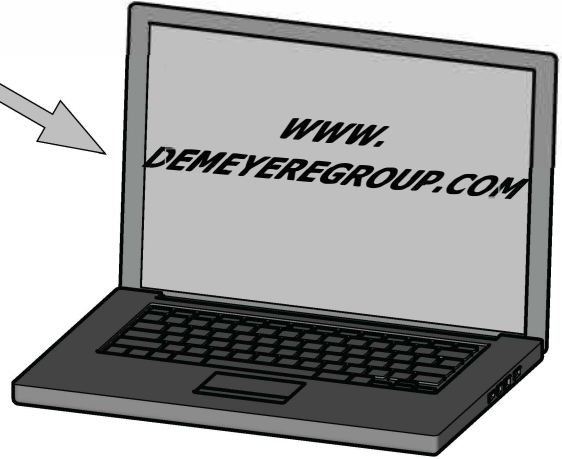
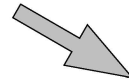
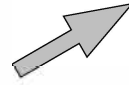
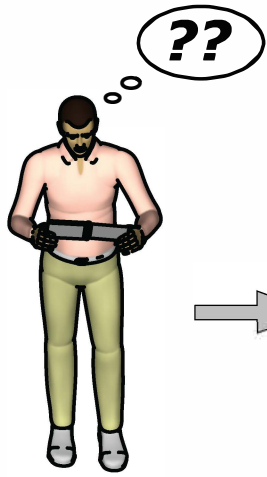
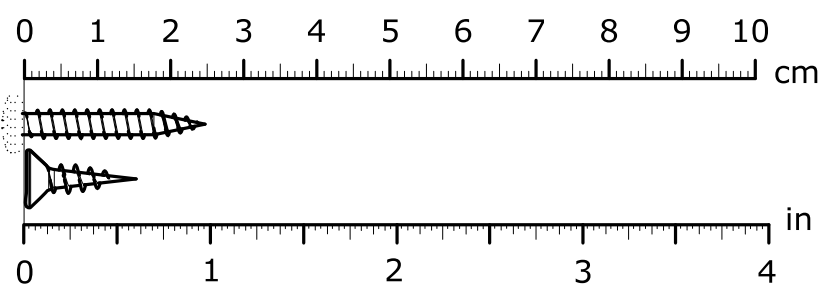
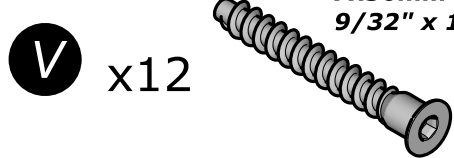
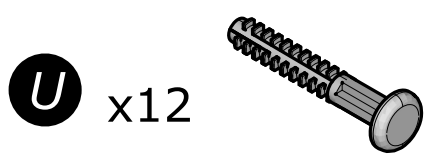
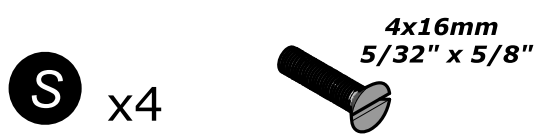
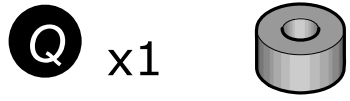
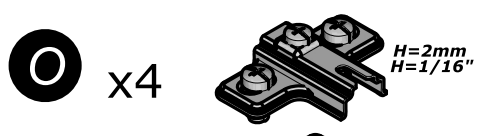
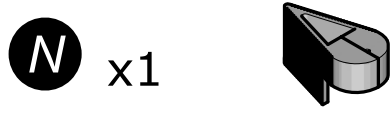
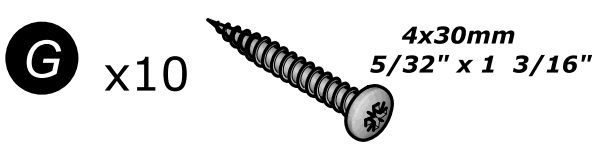
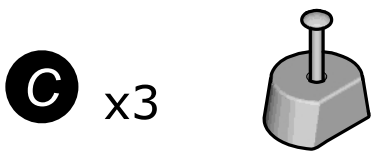
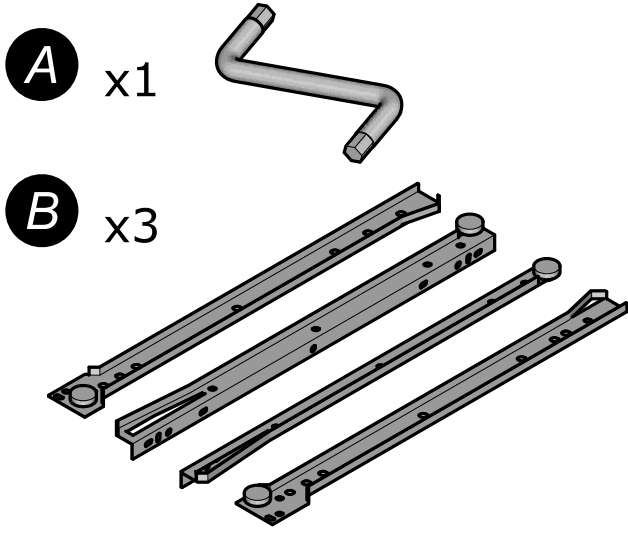

W x2

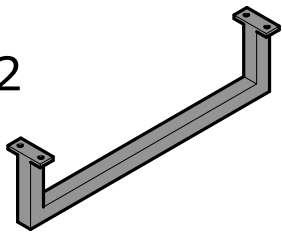

X x1

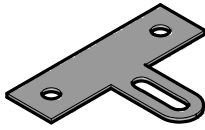

Y x6

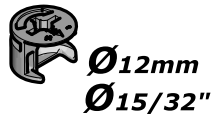

Z x5

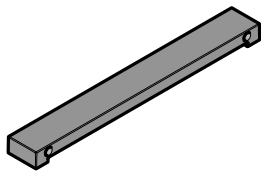

AA x2

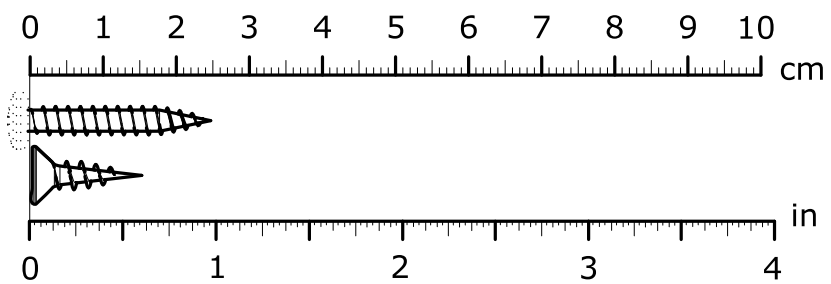
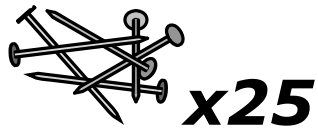

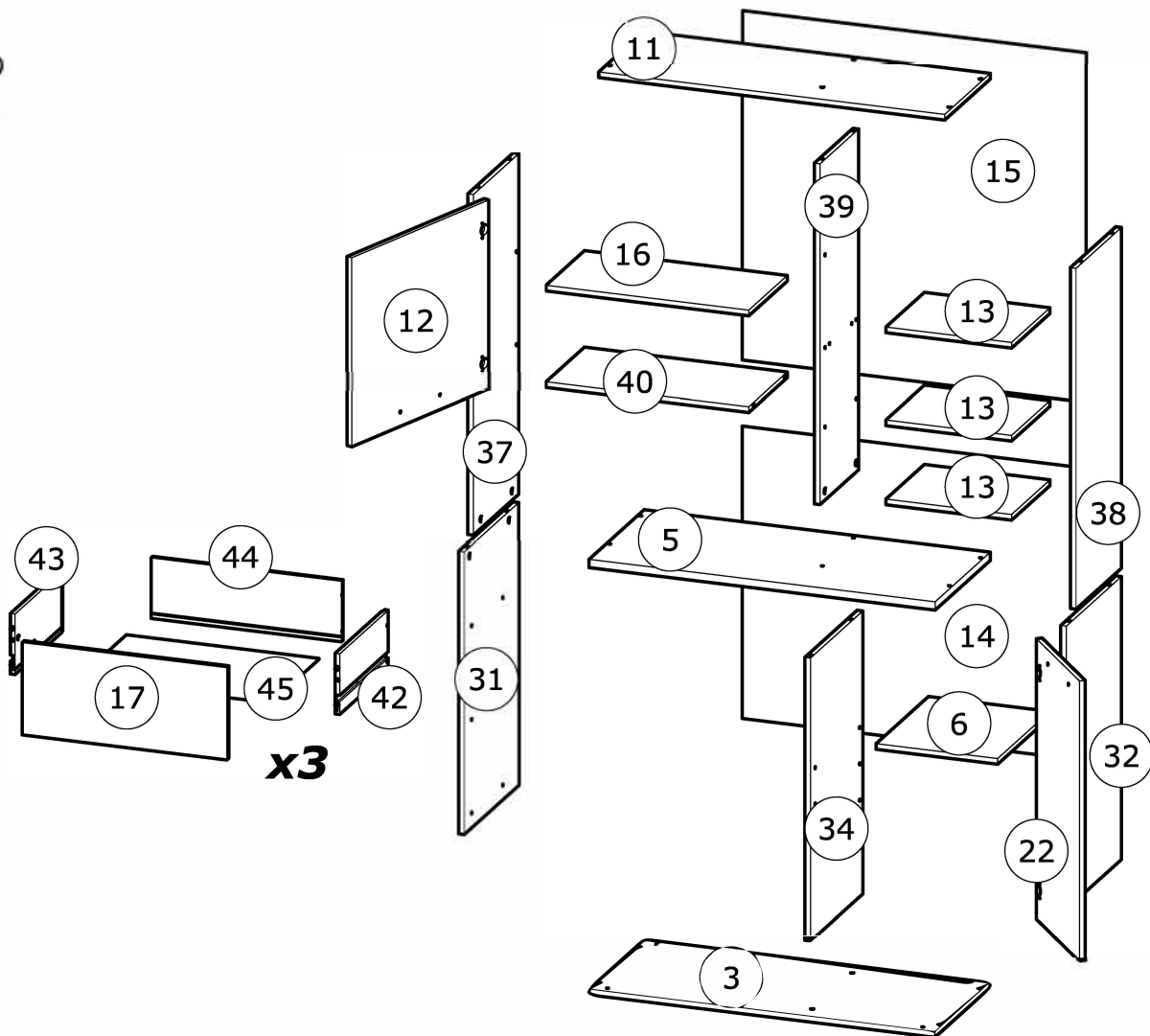

č.	rozměr (mm)		rozměr (palce)		ks
3	920	x 397	36 4/16	x 15 10/16	1
5	920	x 397	36 4/16	x 15 10/16	1
6	323	x 377	12 11/16	x 14 13/16	1
11	920	x 328	36 4/16	x 12 15/16	1
12	500	x 551	19 11/16	x 21 11/16	1
13	334	x 277	13 2/16	x 10 14/16	3
14	914	x 772	36	x 30 6/16	1
15	914	x 924	36	x 36 6/16	1
16	539	x 277	21 4/16	x 10 14/16	1
17	544	x 244	21 7/16	x 9 10/16	3
22	741	x 335	29 3/16	x 13 3/16	1

č.	rozměr (mm)		rozměr (palce)		ks
31	748	x 396	29 7/16	x 15 9/16	1
32	748	x 396	29 7/16	x 15 9/16	1
34	748	x 377	29 7/16	x 14 13/16	1
37	900	x 327	35 7/16	x 12 14/16	1
38	900	x 327	35 7/16	x 12 14/16	1
39	900	x 278	35 7/16	x 10 15/16	1
40	539	x 277	21 4/16	x 10 14/16	1
42	350	x 160	13 12/16	x 6 5/16	3
43	350	x 160	13 12/16	x 6 5/16	3
44	506	x 160	19 15/16	x 6 5/16	3
45	512	x 348	20 3/16	x 13 11/16	3

**CZ**

**VAROVÁNÍ: NÁBYTEK MUSÍ BÝT UCHYČEN KE ZDI ABY SE PŘEDEŠLO JEHO PŘEVHRNUTÍ**

- Při sestavování a instalaci postupujte přesně a pečlivě podle pokynů tohoto návodu k montáži, abyste předešli bezpečnostním rizikům.
- Nábytek uchyťte ke zdi pomocí přichytky, která je součástí dodávky.
- Spojovací materiál pro uchycení ke zdi není součástí dodávky. Použijte spojovací materiál, odpovídající vašemu typu zdi.

**EN**

**WARNING: FURNITURE TO BE ATTACHED TO THE WALL TO PREVENT OVERTURNING**

- Installation shall be carried out exactly according to those instructions-otherwise a safety risk can occur if incorrectly installed;
- Attach the furniture to the wall with the fastening provided for this purpose
- Screw and Pegs are not supplied. Use Screws and pegs adapted to the support.

**DE**

**WARNUNG: DAS MÖBEL MUSS AN DER WAND BEFESTIGT WERDEN, UM ZU VERHINDEN DASS ES KIPPT**

- Um das Produkt korrekt zu installieren und um Risiken für Ihre Sicherheit zu verhindern, die Gebrauchsanleitung genauestens befolgen.
- Das Möbel mit den vorgesehenen Befestigungen an einer Wand befestigen.
- Schrauben und Dübel sind nicht im Lieferumfang enthalten. Passende Schrauben und Dübel verwenden.

**ES**

**ADVERTENCIA: ESTE MUEBLE DEBE ESTAR SIEMPRE FIJO EN LA PARED PARA EVITAR QUE VUELQUE**

- Para instalar correctamente este producto y eliminar los riesgos para la seguridad, seguir exactamente las instrucciones del manual.
- Fijar el mueble a la pared con las sujeciones previstas a este efecto.
- Los tornillos y los tacos no están incluidos. Utilizar tornillos y tacos adaptados al soporte.

**NL**

**WAARSCHUWING: MEUBEL MOET VERPLICHT AAN DE MUUR BEVESTIGD WORDEN ZODAT HET NIET KAN OMVALLEN**

- Om dit product correct te installeren en alle risico's voor uw veiligheid te elimineren, gelieve de instructies in deze handleiding nauwgezet op te volgen.
- Zet het meubel vast aan de muur met de hiertoe voorziene bevestigingen.
- De schroeven en pluggen zijn niet meegeleverd. Gebruik schroeven en pluggen die geschikt zijn voor het materiaal van de muur.

**IT**

**AVVERTENZA: MOBILE DA FISSARE IMPERATIVAMENTE AL MURO PER EVITARE CHE SI RIBALTI**

- Per installare correttamente questo prodotto ed eliminare i rischi per la vostra sicurezza, si prega di seguire esattamente il manuale d'istruzioni.
- Fissare il mobile al muro con gli appositi ganci.
- Le viti e i tasselli non sono forniti. Utilizzare viti e tasselli adatti al supporto.

**PT**

**ADVERTÊNCIA: MÓVEL A FIXAR OBRIGATORIAMENTE À PAREDE PARA EVITAR A SUA QUEDA**

- Para instalar corretamente este produto e eliminar os riscos para a sua segurança, é favor seguir exatamente este manual de instruções.
- Fixe o móvel à parede com as fixações previstas para o efeito
- Os parafusos e as cavilhas não são fornecidos. Utilize parafusos e cavilhas adaptados ao suporte.

**PL**

**OSTRZEŻENIE: MEBEL NALEŻY PRZYMOCOWAĆ DO ŚCIANY, ABY UNIKNĄĆ JEGO PRZEWRÓCENIA**

- Aby prawidłowo zainstalować ten produkt i wyeliminować zagrożenie dla bezpieczeństwa użytkownika, należy postępować zgodnie z niniejszą instrukcją.
- Przymocować mebel do ściany za pomocą mocowań przewidzianych w tym celu.
- Śruby i nakrętki nie znajdują się w zestawie. Użyć śrub i nakrętek dostosowanych do wspornika.

**CR**

**UPOZORENJE : UČVRSTITE ORMARIĆ NA ZID KAKO BISTE SPRIJEČILI NJEGOVO LJULJANJE**

- Kako biste pravilno postavili ovaj proizvod i uklonili sigurnosne rizike kojima se izlažete, pridržavajte se strogo ovog priručnika s uputama.
- Postavite ormarić na zid pripadajućim sponama.Vijci i svornjci ne isporučuju se. Upotrijebite nosne vijke i svornjke.

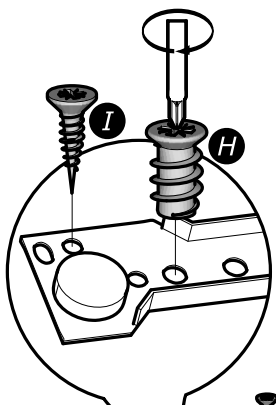
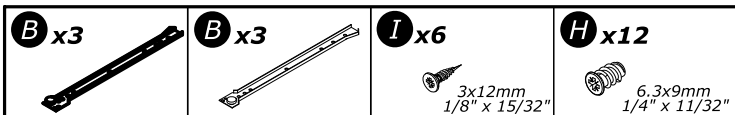

www.Demeyere.fr

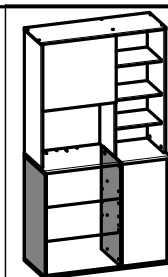
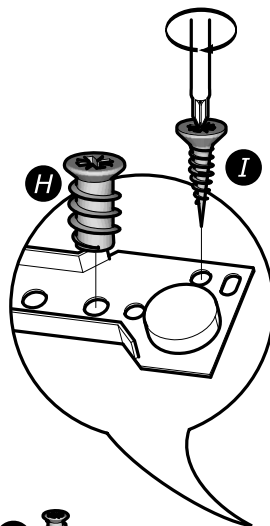

1

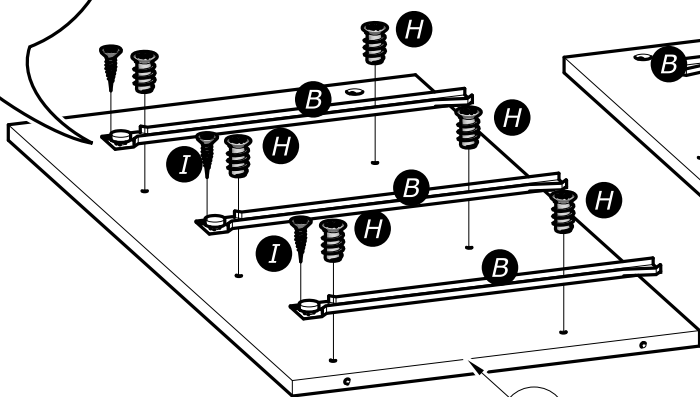

31

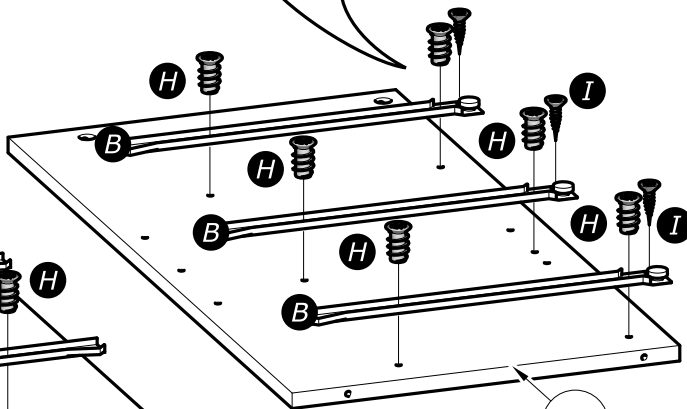

34

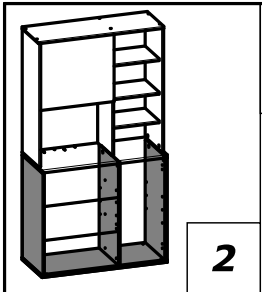

2

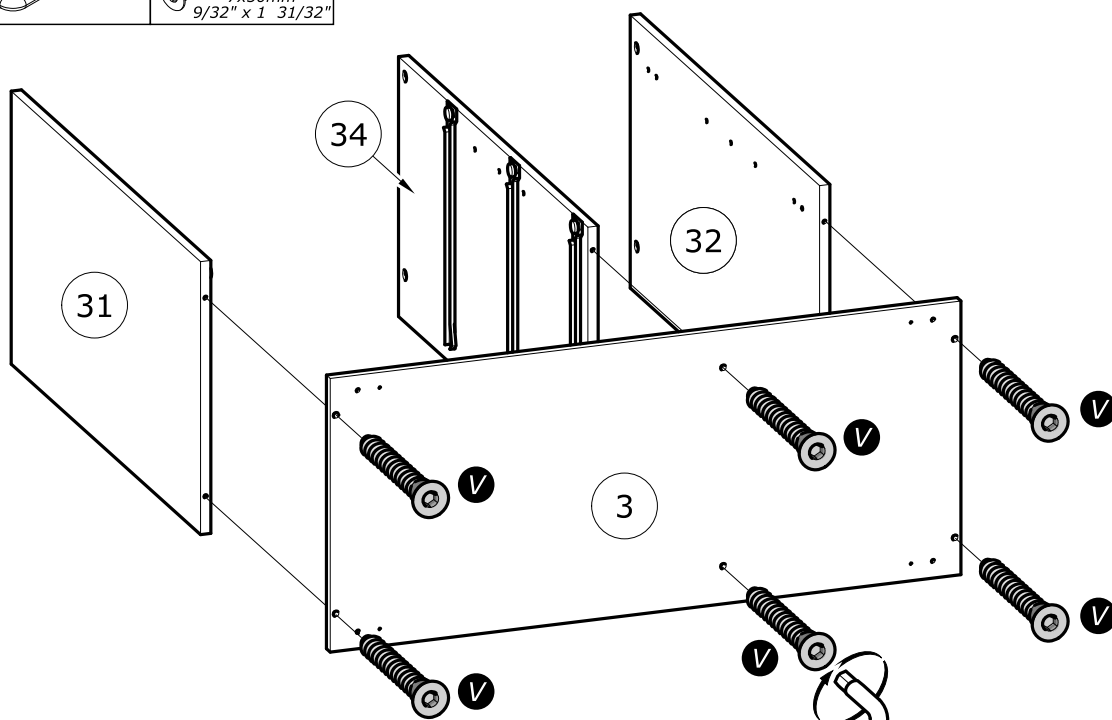
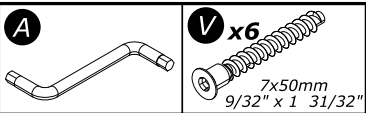

31

34

32

3

A

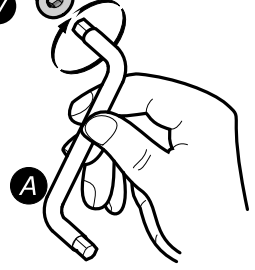

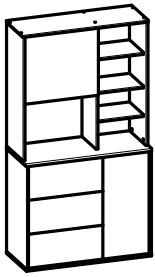

3

**R** x4

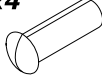

**S** x4



4x16mm  
5/32" x 5/8"

**F** x4



3x16mm  
1/8" x 5/8"

**W** x2

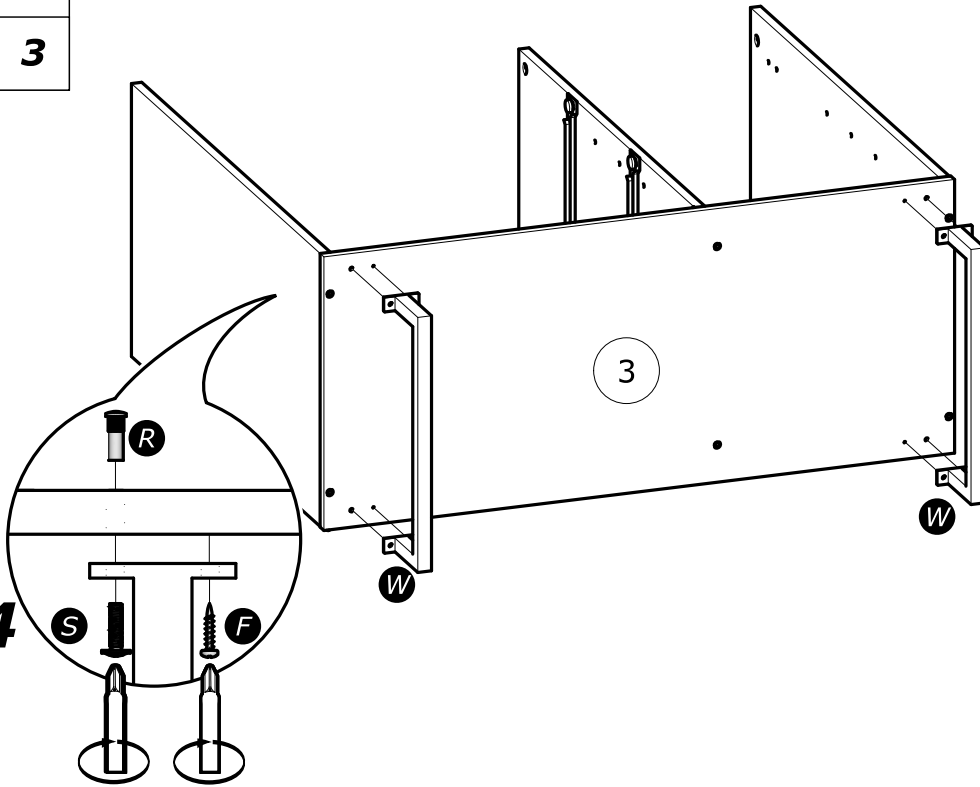

x4

**S**

**F**

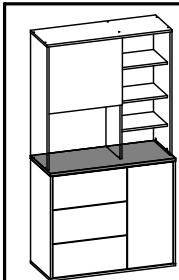

4

**L** x6

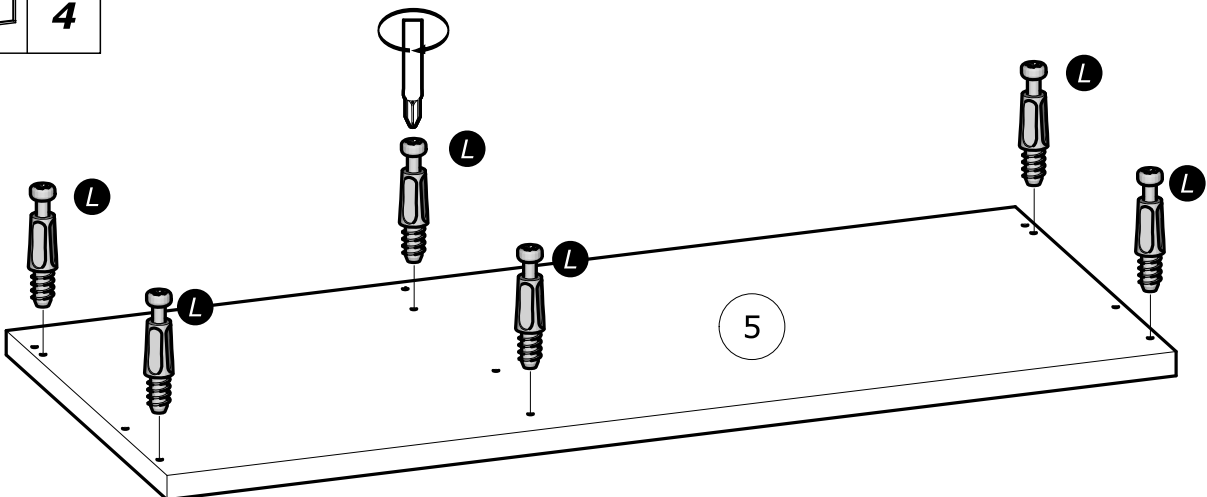
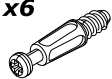



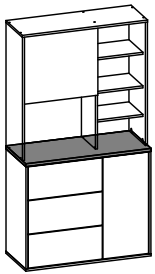

5

**M** x6  
Ø15mm  
Ø19/32"

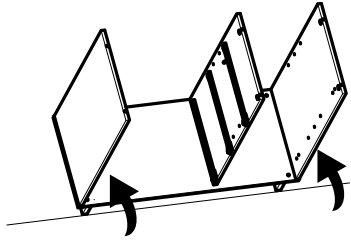
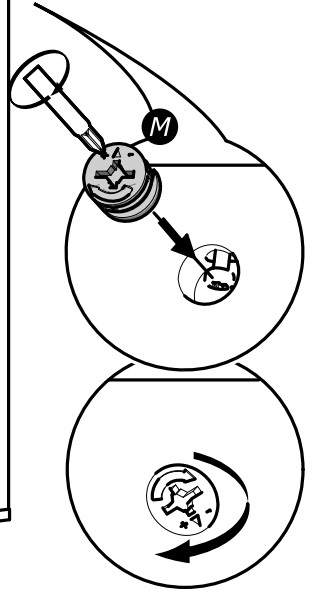
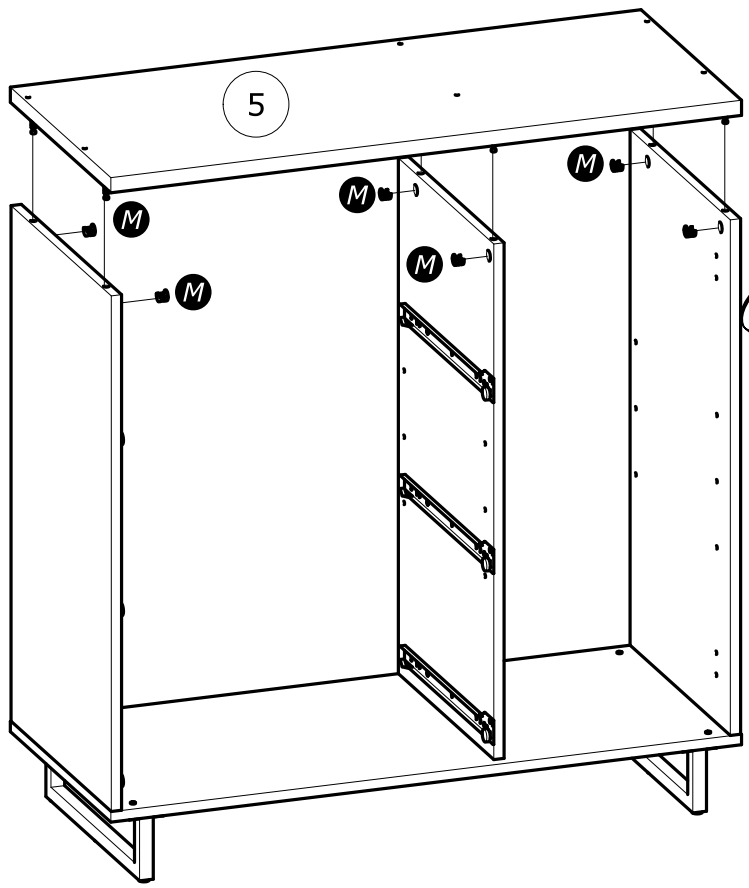

x2

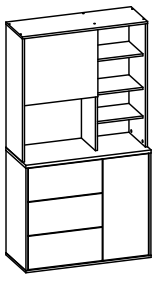

6

**L** x6

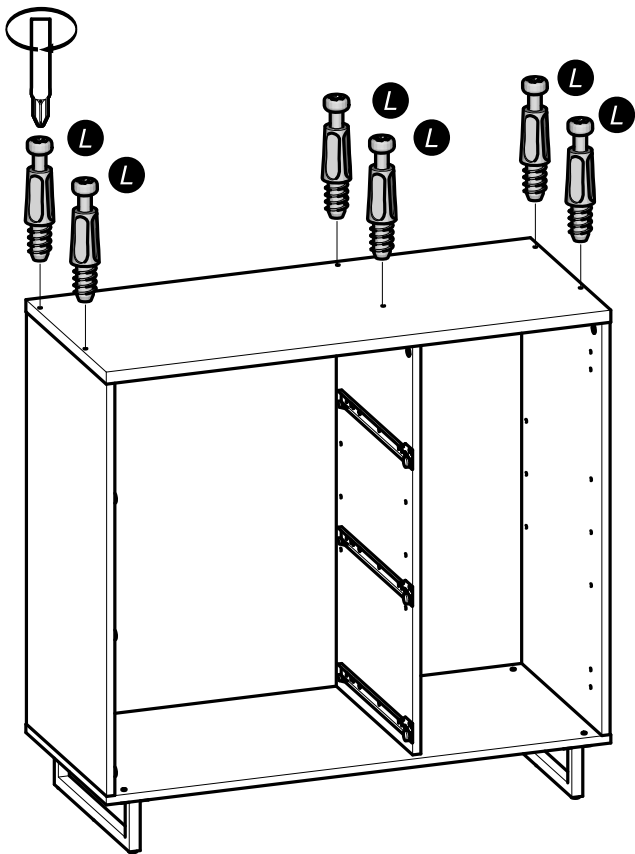

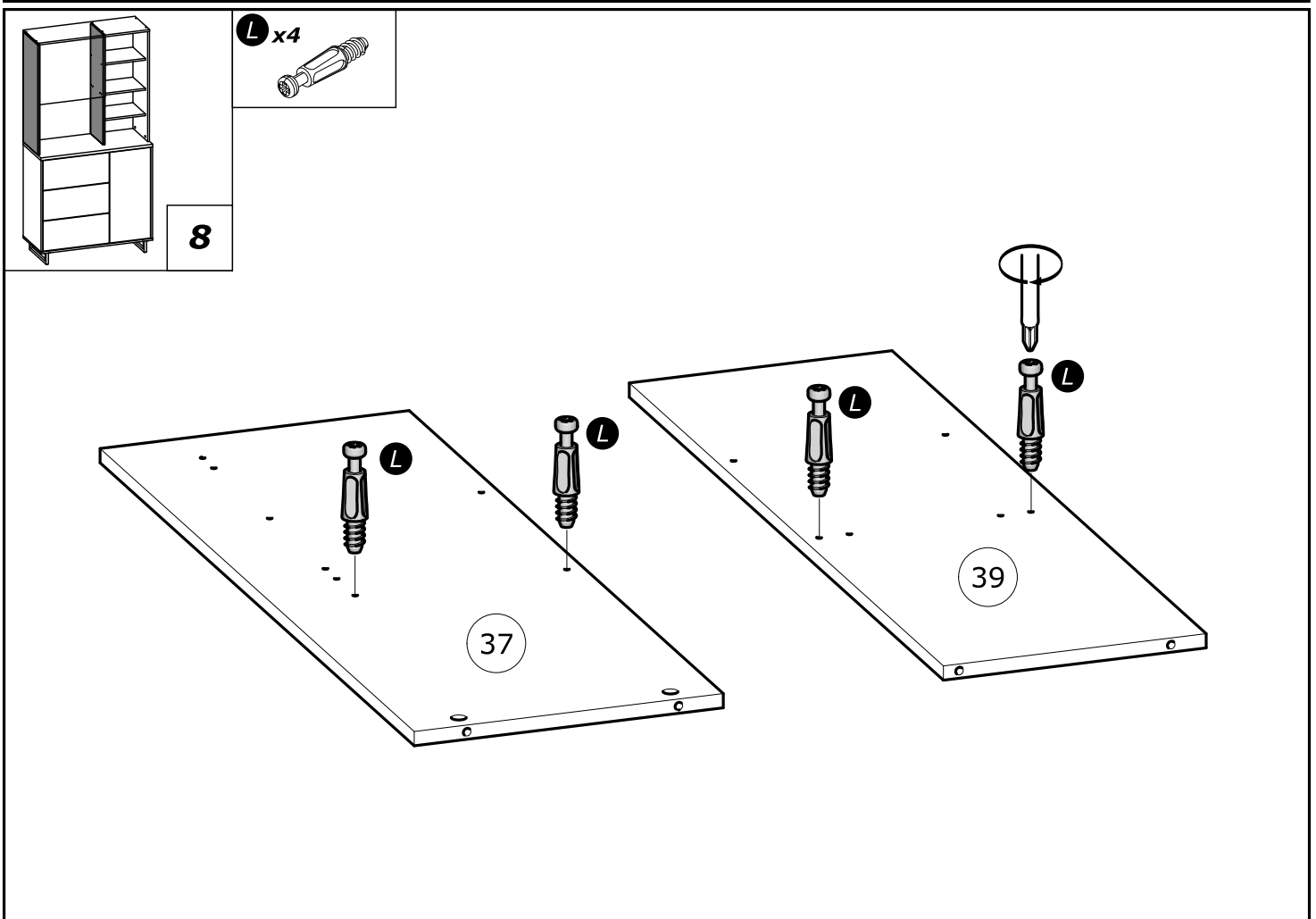
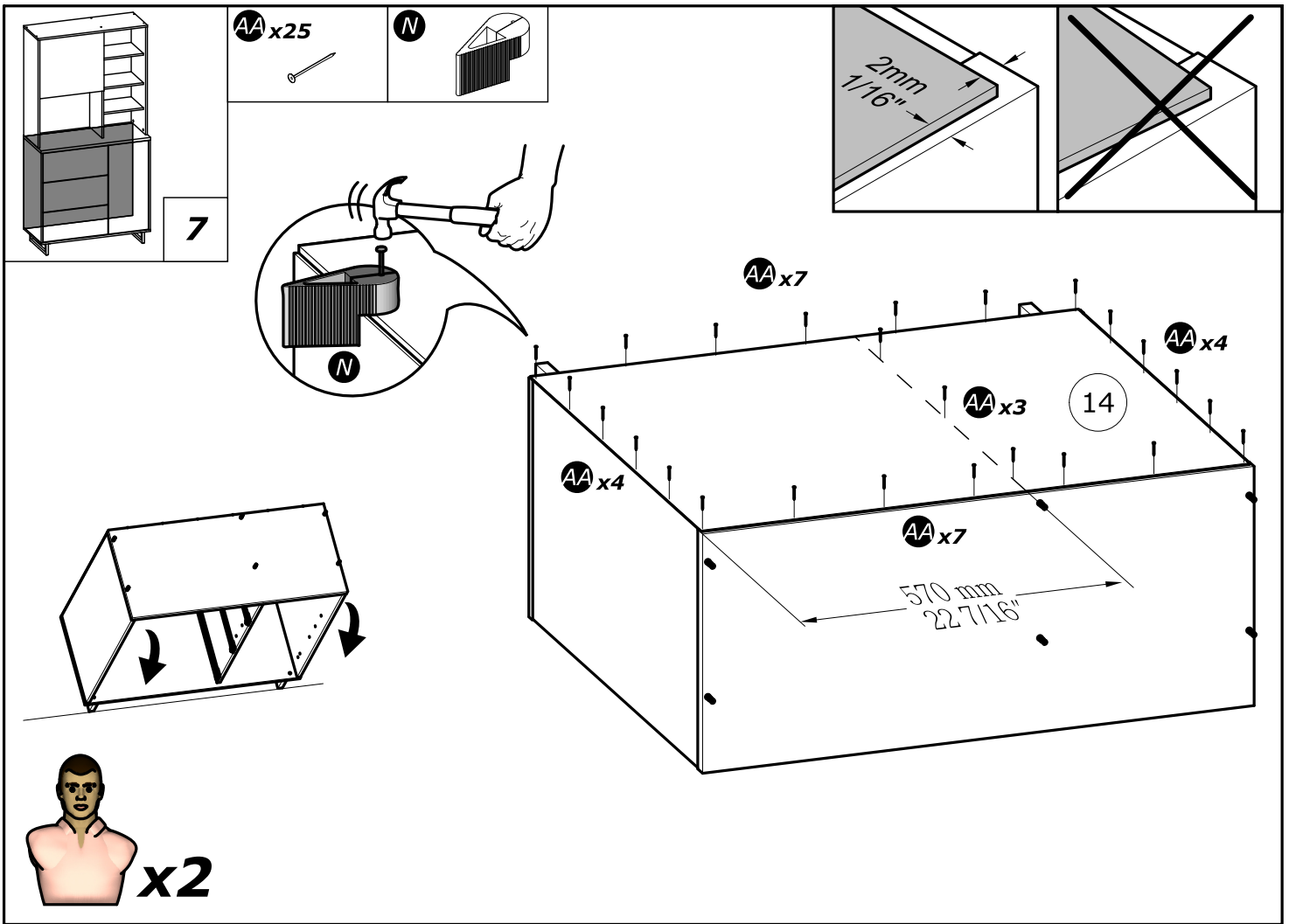

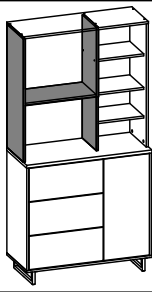

9

M x4  
Ø15mm  
Ø19/32"

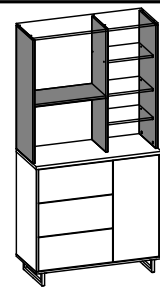
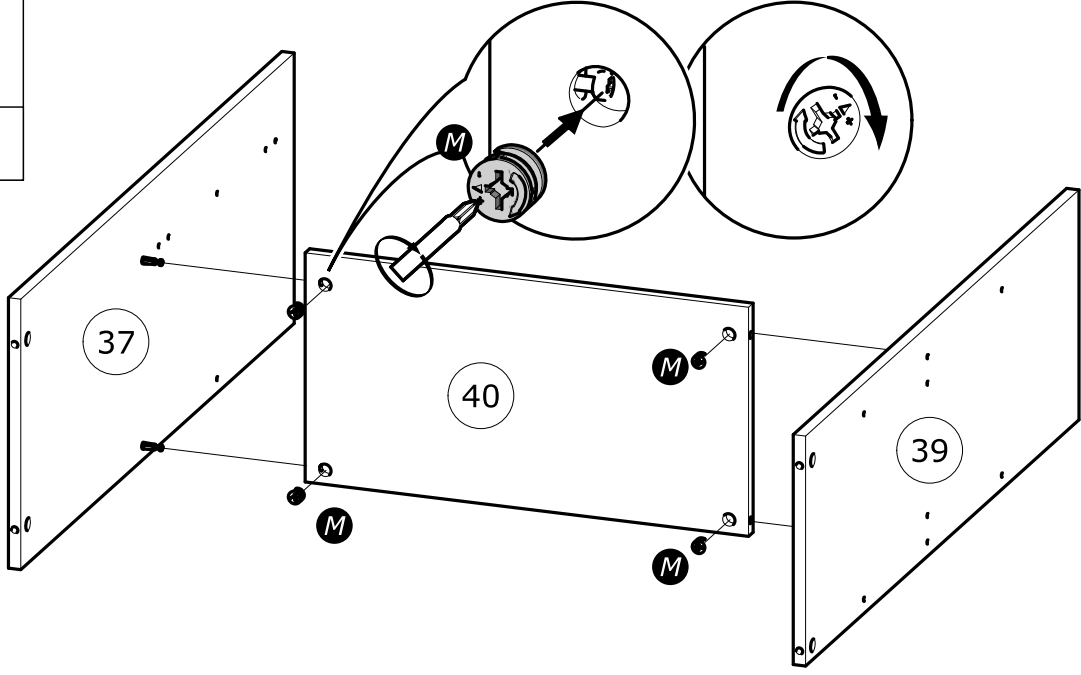

10

M x6  
Ø15mm  
Ø19/32"

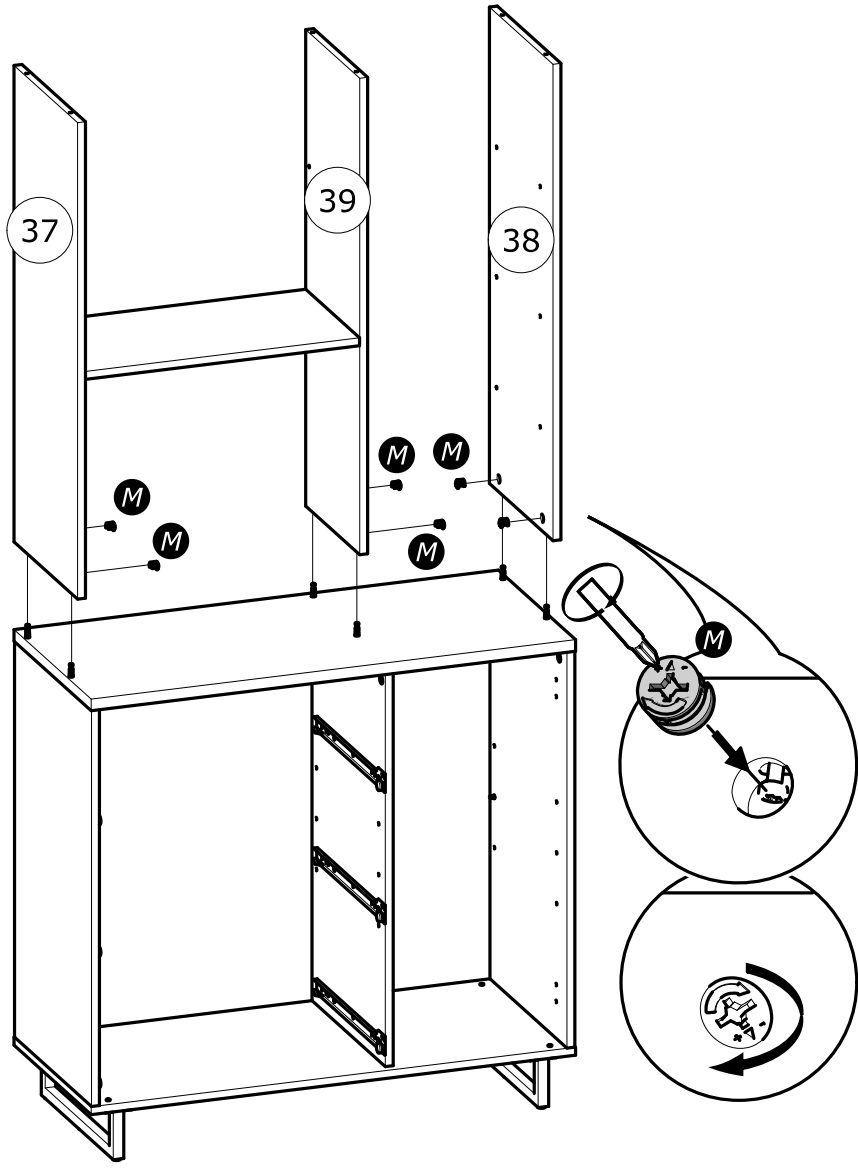

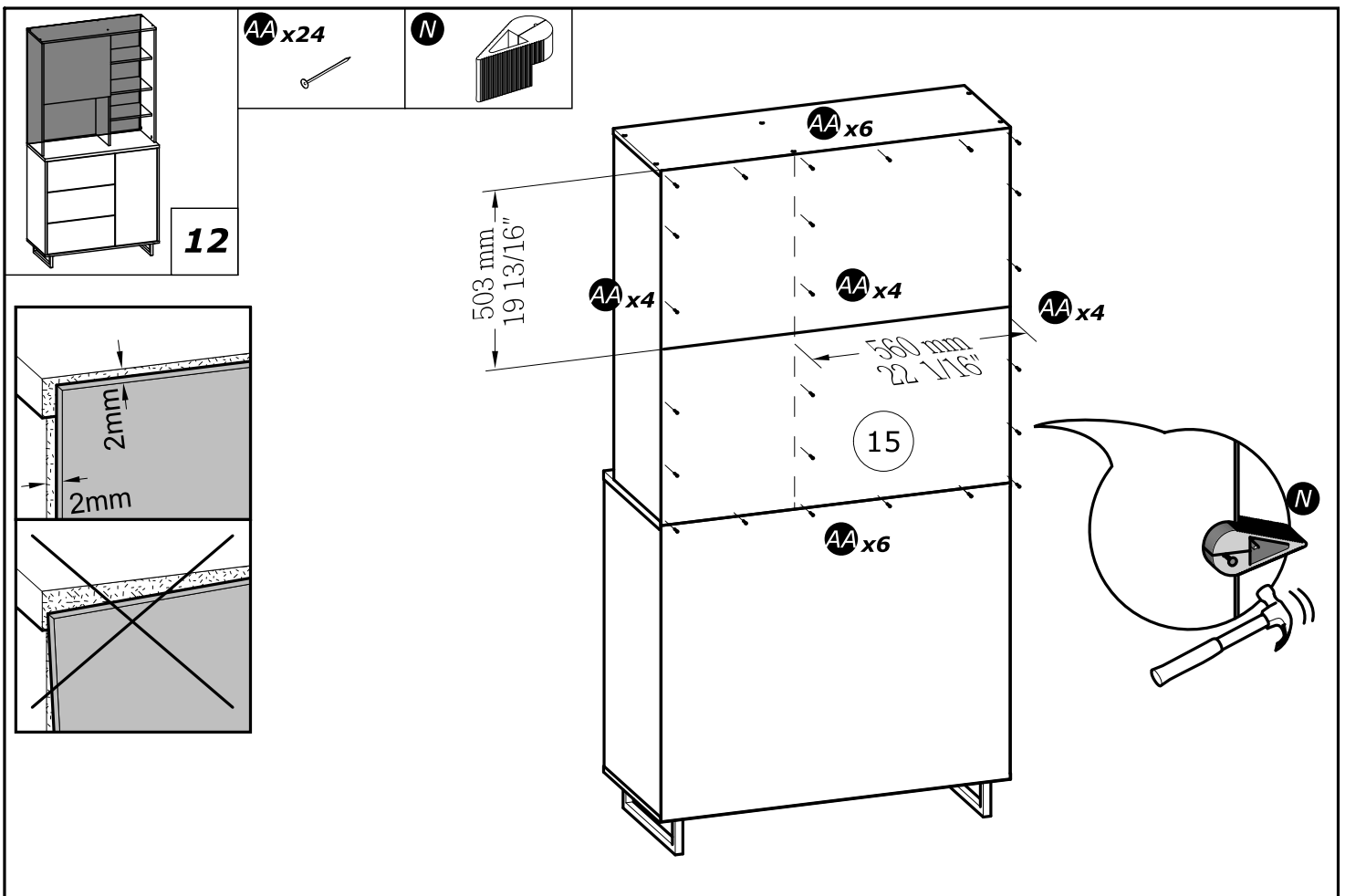
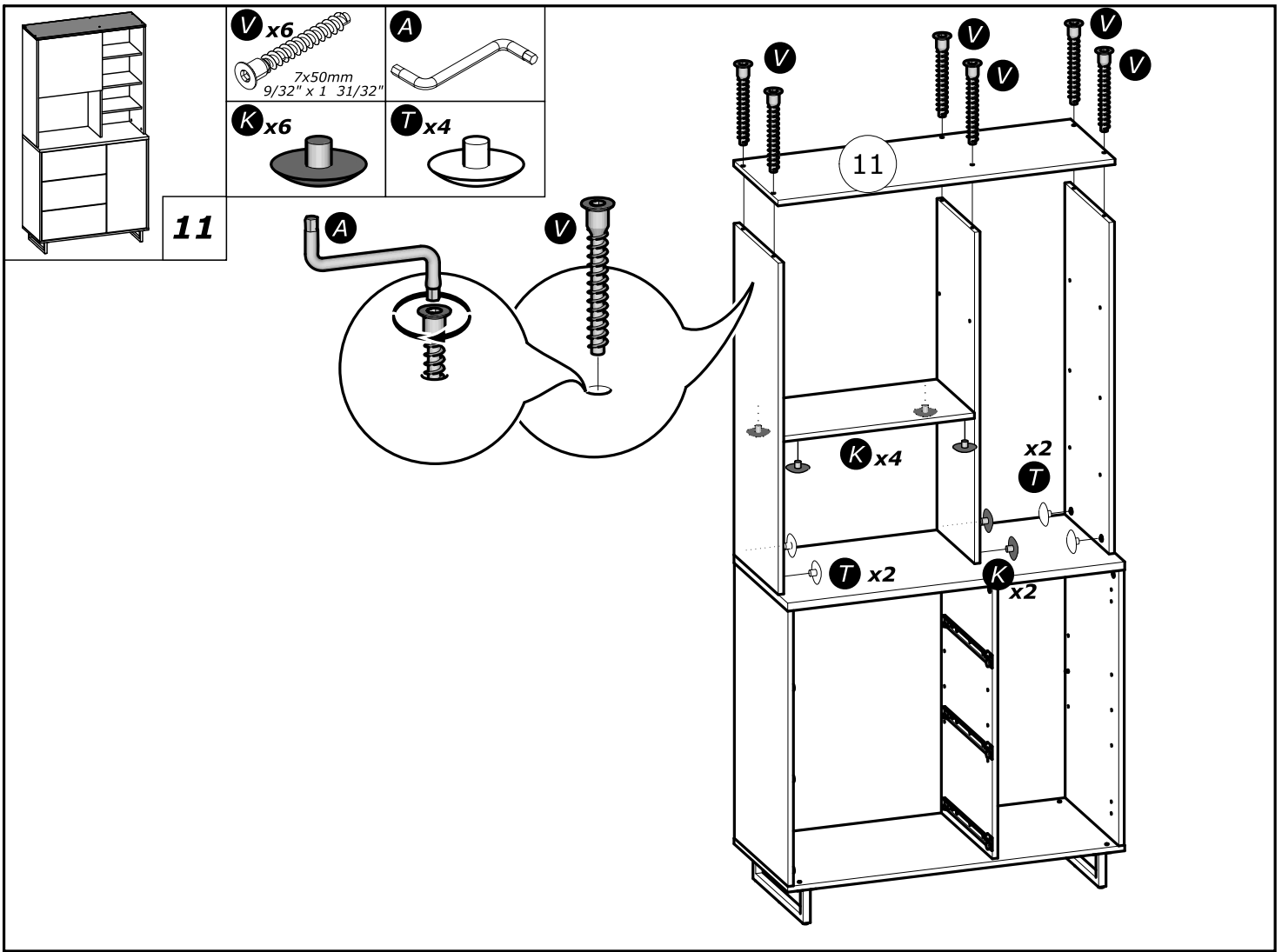

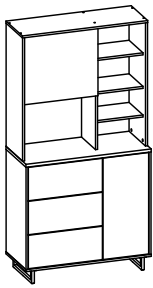

13

**E** x2

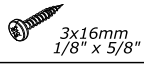

**Q** x1



**X** x1

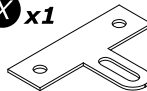

1°

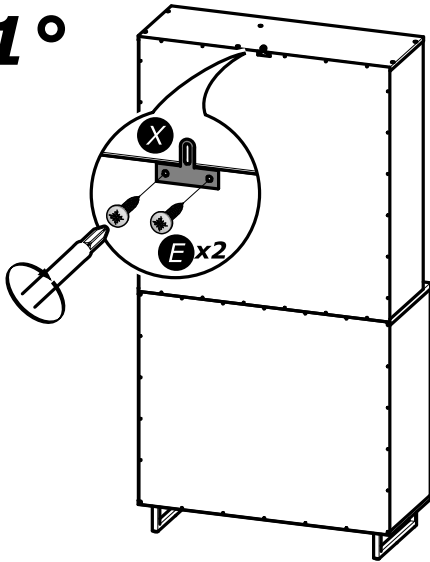

2°

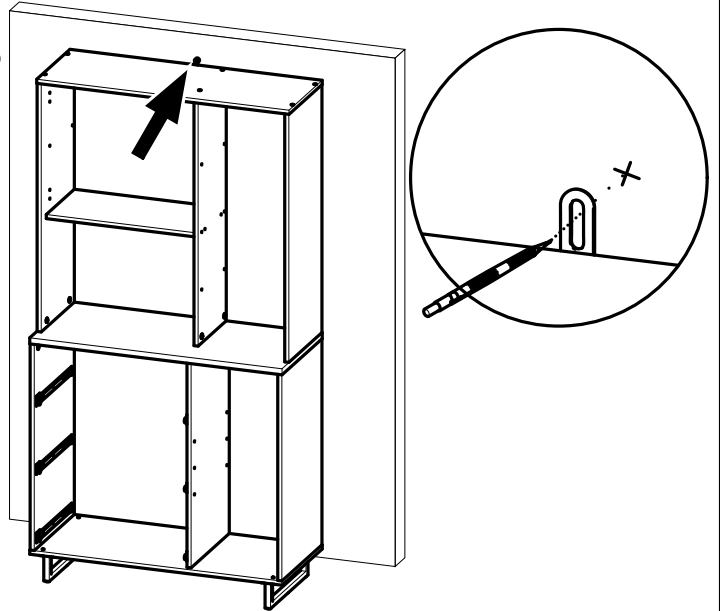

3°

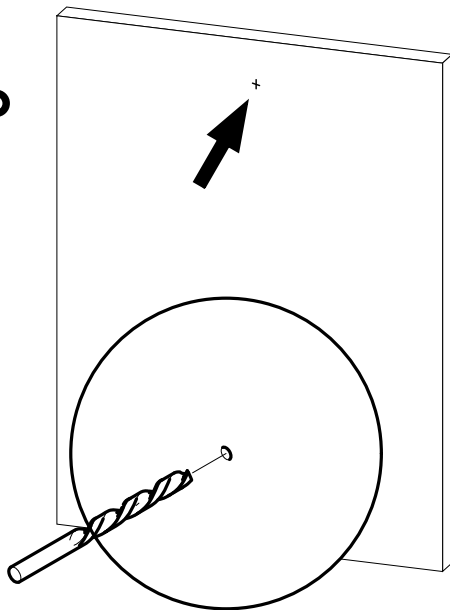

4°

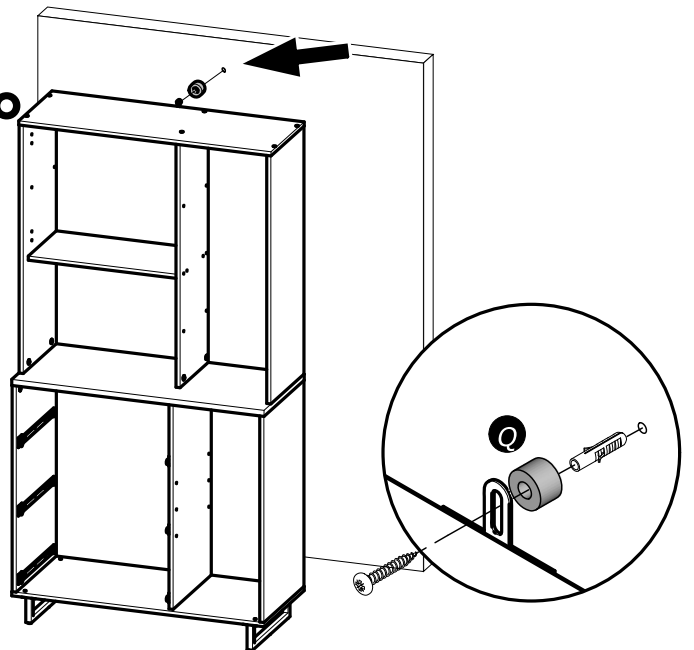

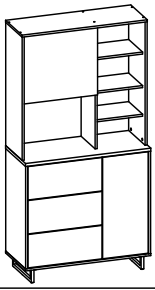

14

O x4

H=2mm  
H=1/16"

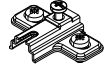

P x4



x4

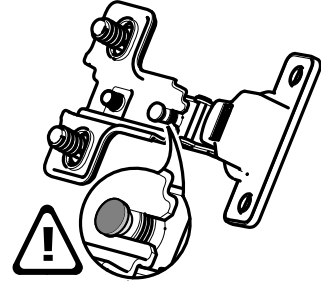
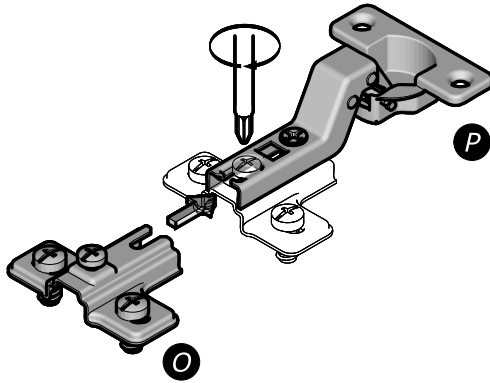

www.Demeyere.fr

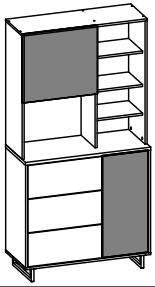

15

J x8

3.5x15mm  
1/8" x 19/32"

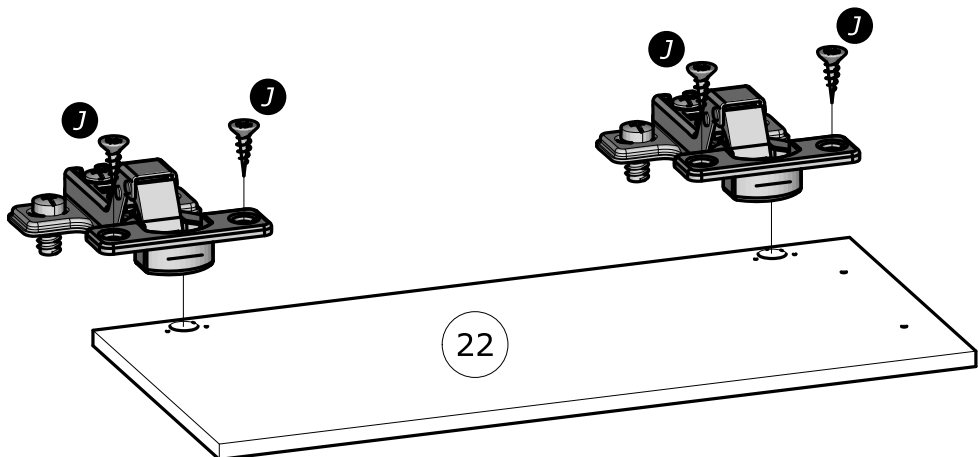
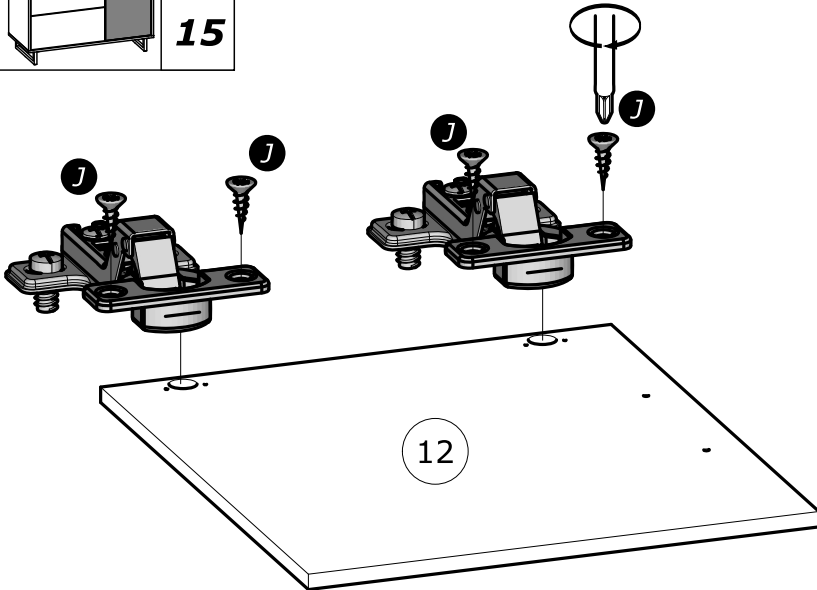

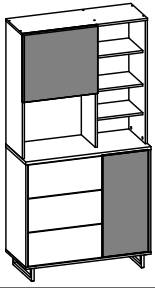

16

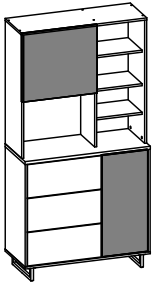
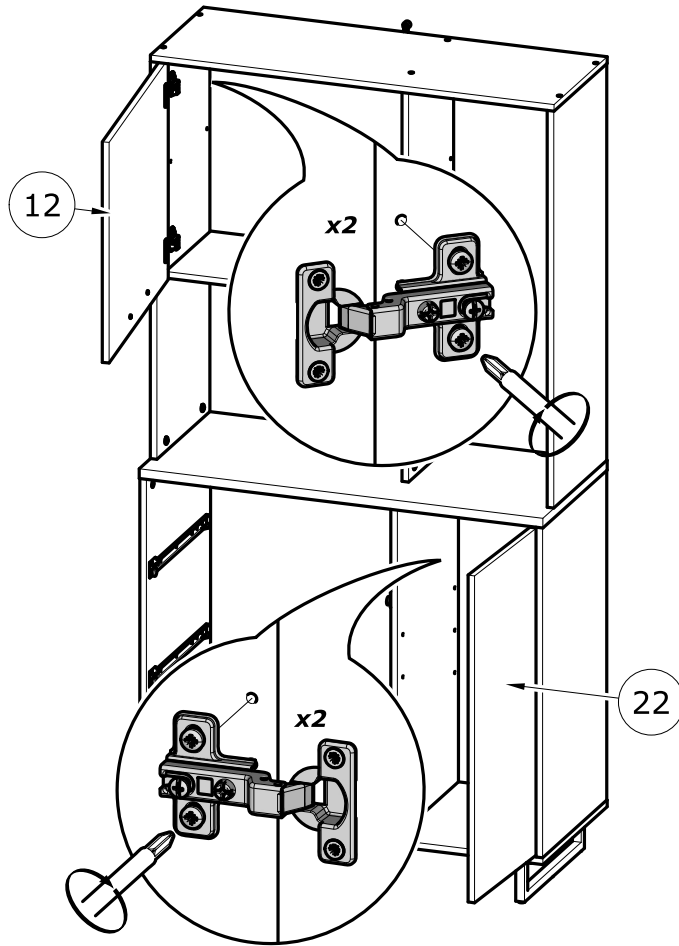

17

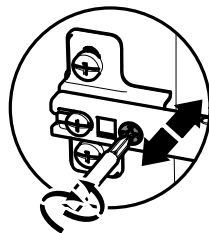
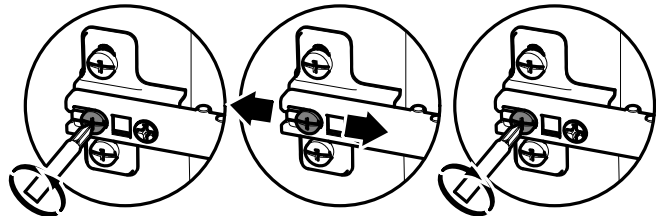
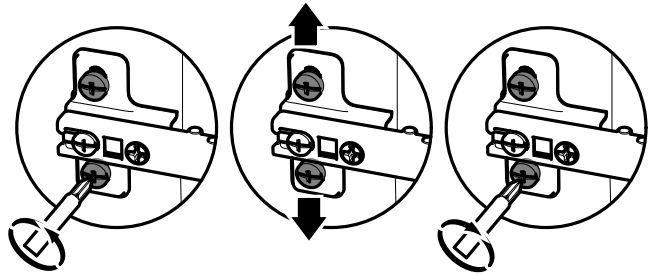
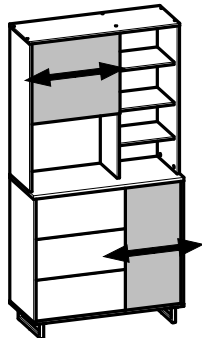
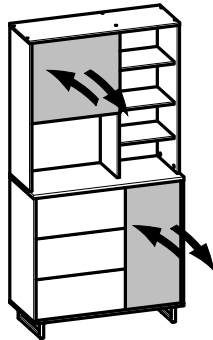
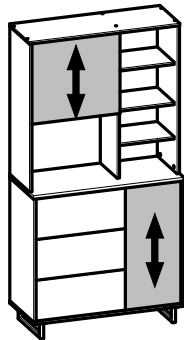

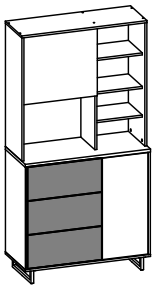

18

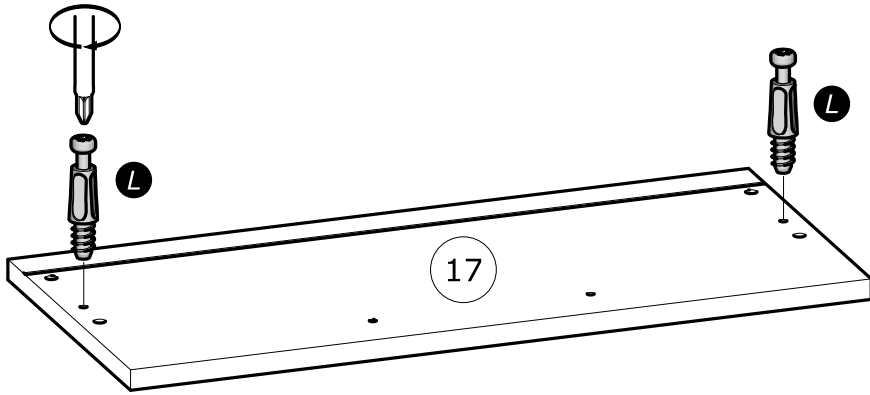
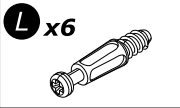

x3

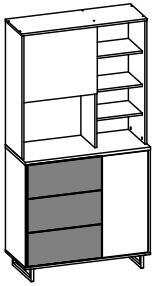

19

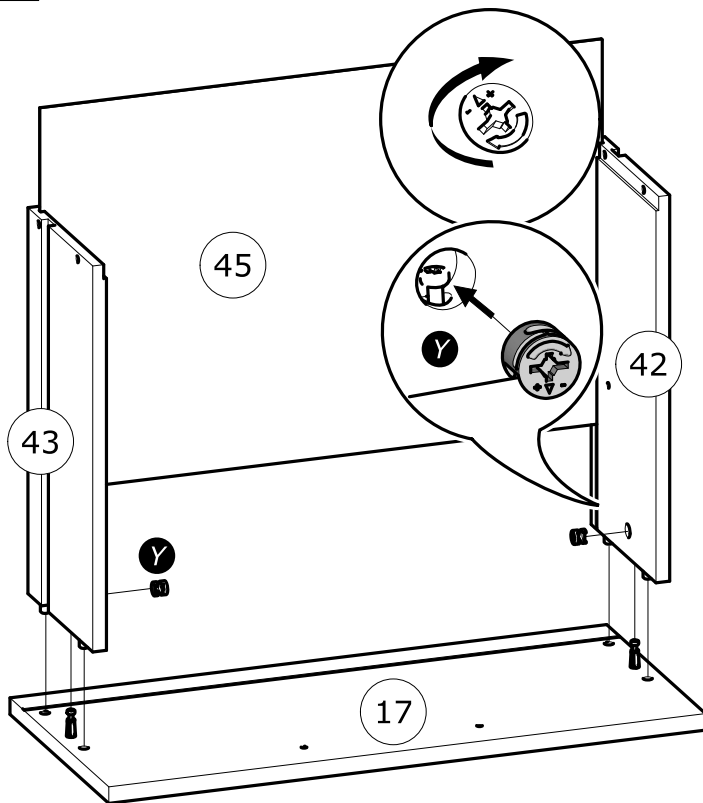

x3



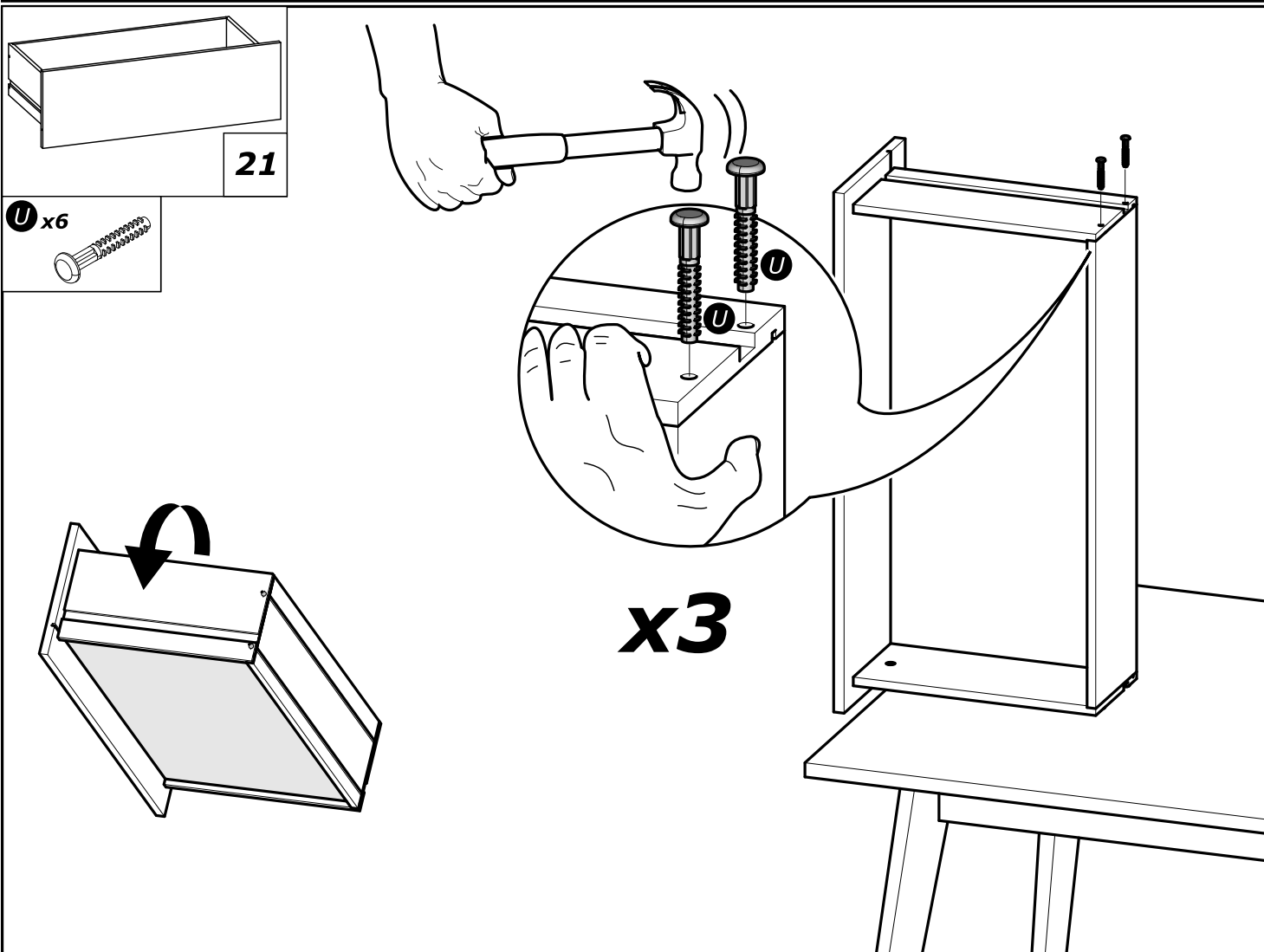
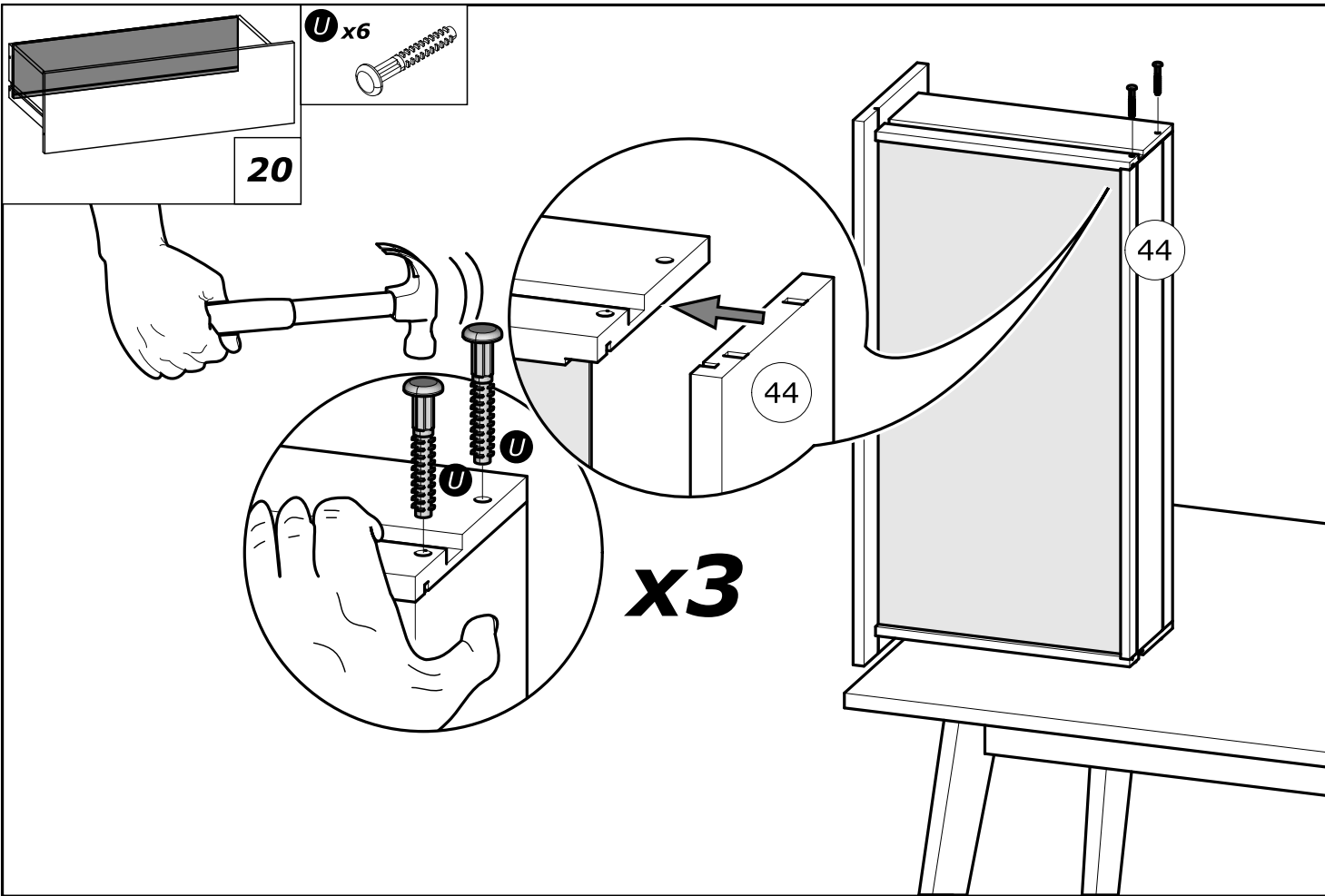

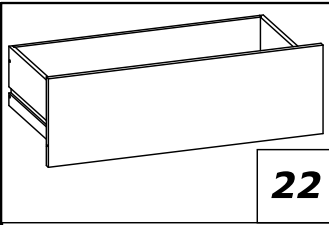

**I** x12  
3x12mm  
1/8" x 15/32"

**B** x3

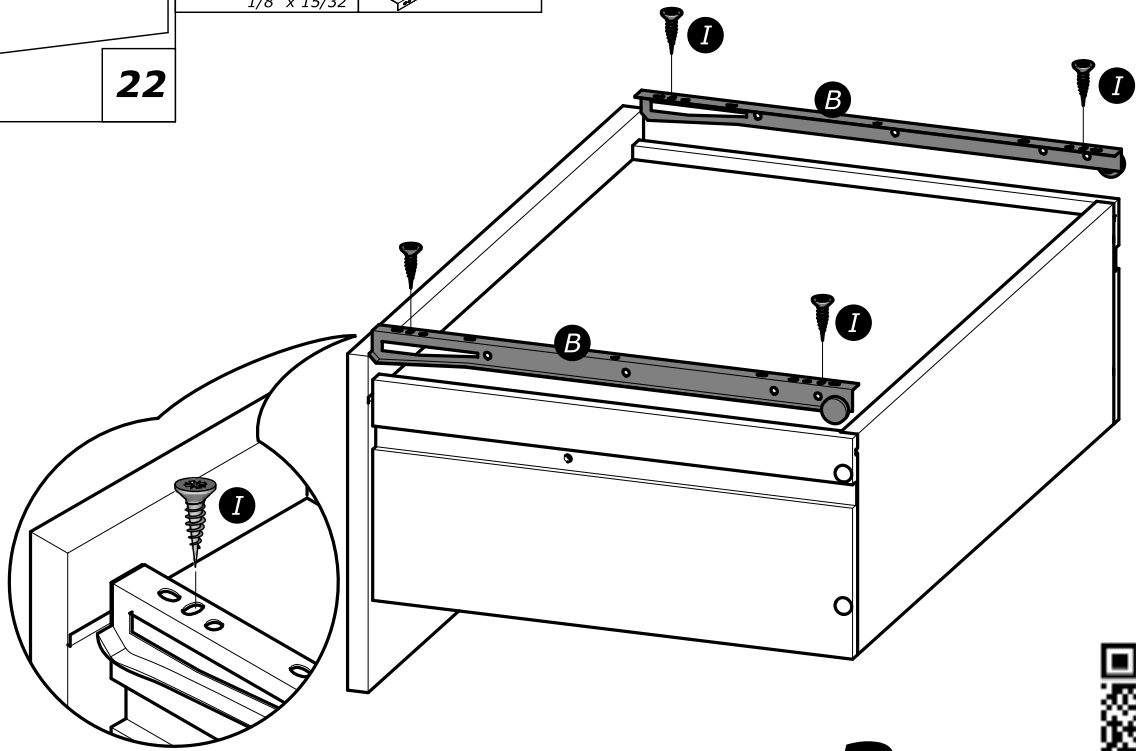

**x3**



[www.Demeyere.fr](http://www.Demeyere.fr)

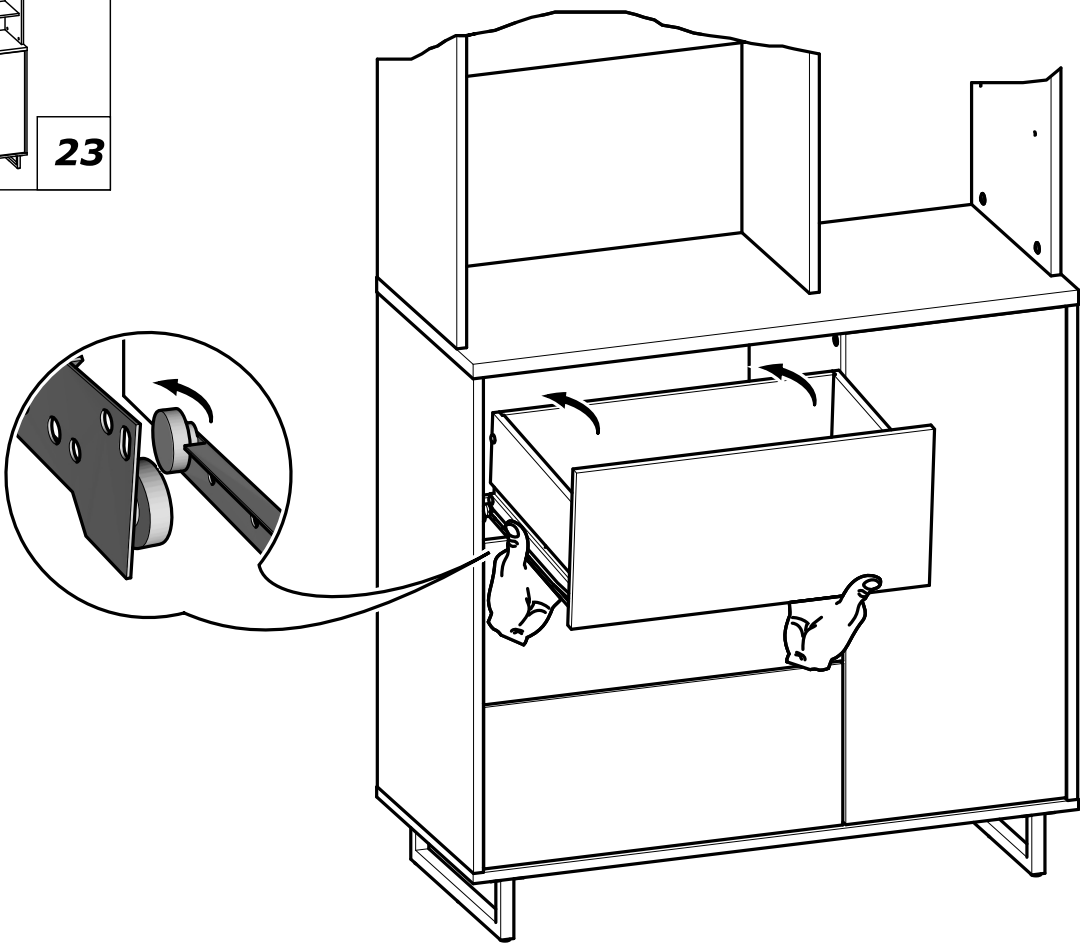
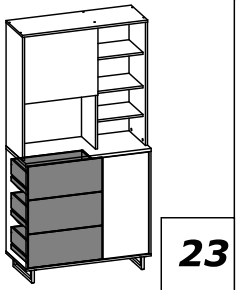

[www.Demeyere.fr](http://www.Demeyere.fr)

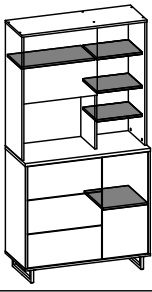

24

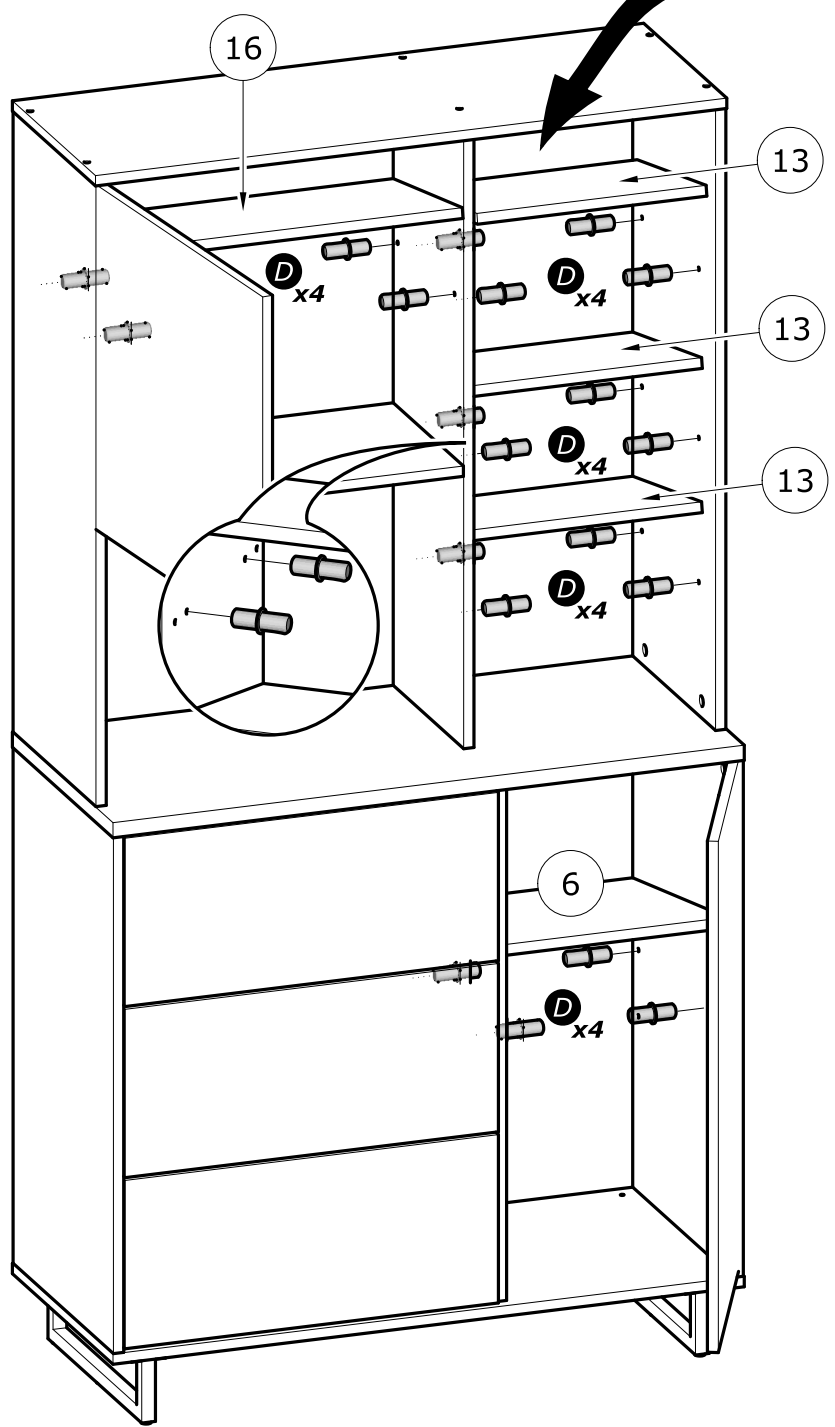
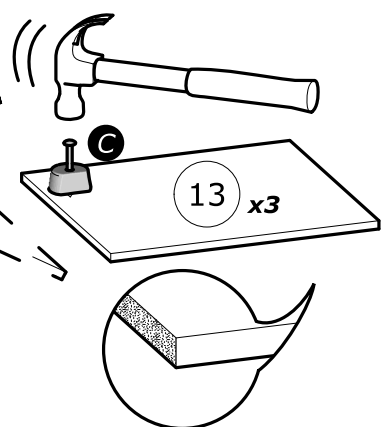
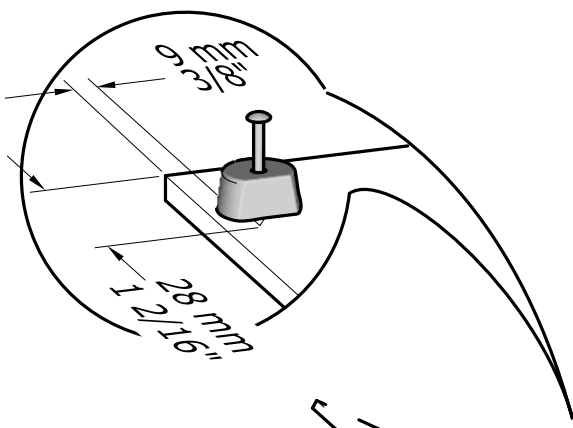
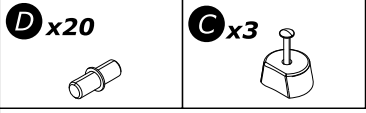

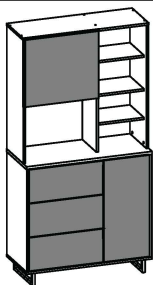

25

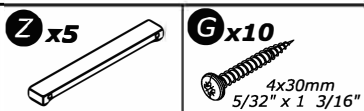

[www.Demeyere.fr](http://www.Demeyere.fr)

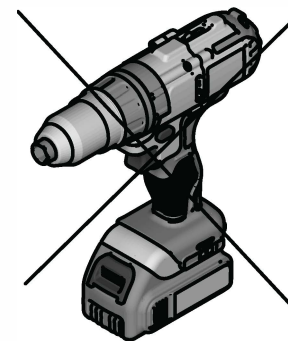
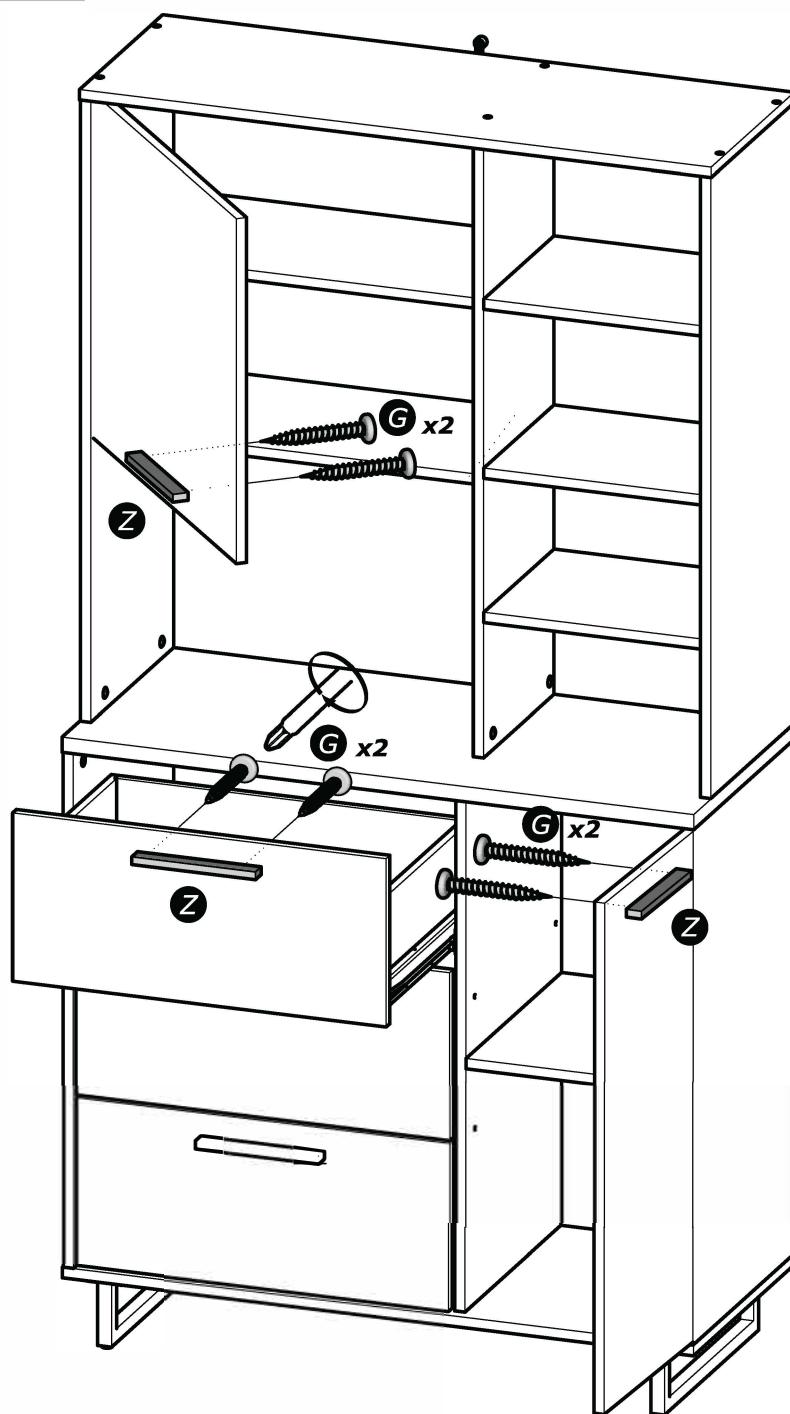

**Panely na bázi dřeva (dřevotřískové desky, dřevovláknité desky, překližka atd.), ze kterých je nábytek zhotoven, mohou do vnitřního ovzduší emitovat znečišťující látky. Proto se doporučuje po instalaci nábytku místnost často větrat, a to nejméně po čtyři týdny, pro snížení expozice znečišťujících látek emitovaných panely.**



**Tříd'te odpad**